

SCT SERIES PRE-SET TENSION SAFE-T-CABLE® APPLICATION TOOL

SEE PAGE 10 FOR IMPORTANT INFORMATION CONCERNING LIMITED WARRANTY, AND LIMITATION OF LIABILITY

INTRODUCTION

The Daniels SCT Series Safe-T-Cable® application tool is designed to terminate ferrules to Safe-T-Cable® in accordance with SAE specification AS4536*. The application tool is compatible with Safe-T-Cable® kits identified in SAE specifications AS3509*, AS3510* and AS3511*.

The following steps are important to assure proper Safe-T-Cable® applications:

1. Proper Tool Calibration (Section 1.0)
2. Proper Cable Installation (Section 2.0)
3. Proper Loading and use of the application tool (Section 3.0)
4. Verification of Proper application (Section 4.0)

* SAE publications are available from:
SAE, International
400 Commonwealth Drive
Warrendale, PA 15096-0001

1.0 TOOL CALIBRATION AND MAINTENANCE

1.1 Checking Indenter Calibration with the Daniels SCT-TB1 Test Fixture

- 1.1.1. Indenter calibration should be checked periodically and must be checked after the nose assembly has been removed or interchanged.
- 1.1.2. Thread the cable into the left swivel and through the right swivel, holding the lever in the home position as shown in Figure 1. If the lever is not kept in the home position the results may be adversely affected. Terminate the cable per section 3.0, making sure to close the handles completely.
- 1.1.3. Apply approximately 2 Lb force to the cable with your finger (or use the Daniels SCTD013 Retention Tester) at the line marked "TEST AREA". If the cable touches either the side or bottom surface of the test area, remove the cable from the test block and terminate another cable as described above, holding the tool perpendicular to the cable.

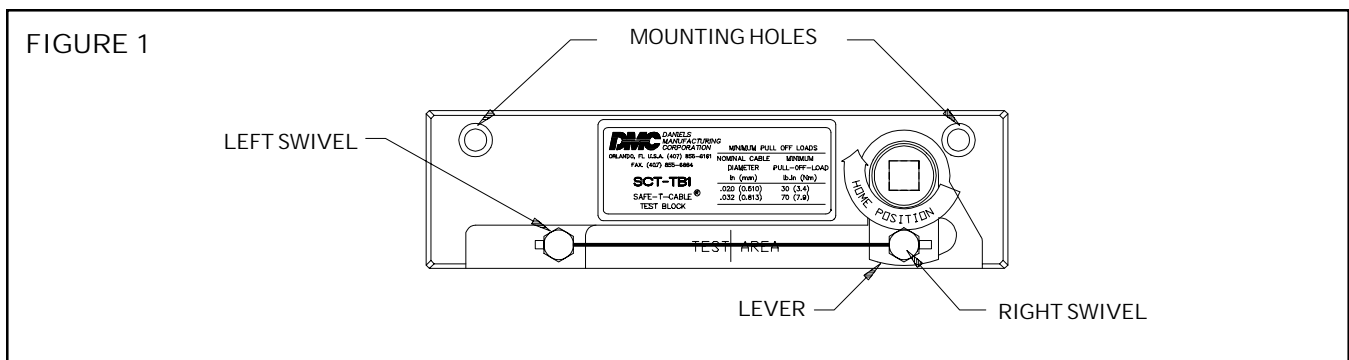

- 1.1.4. Place a calibrated 3/8" drive torque wrench (Daniels SCTD0001) into the square drive hole, orienting the test block and torque wrench on a flat surface as shown in Figure 2. Apply the proper pull-off load as shown in Table 2. Release torque when minimum pull-off load is achieved. Do not apply additional

FIGURE 2

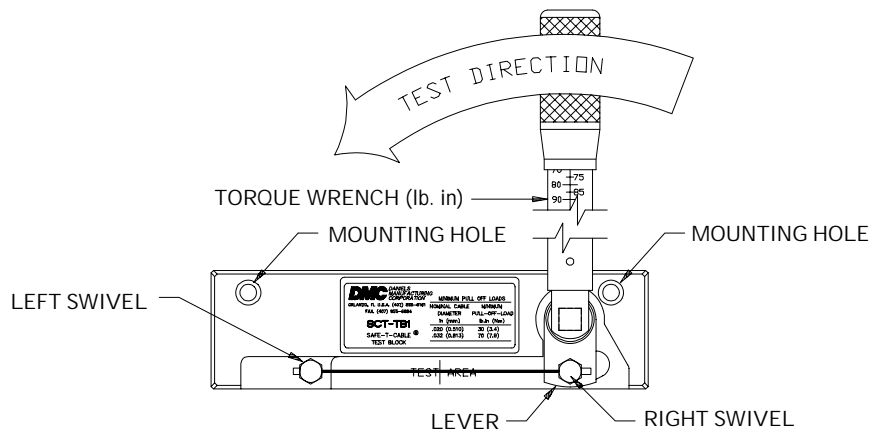

tension to the cable.

- 1.1.5. If the cable did not break or pull out of the ferrule after applying proper torque, remove the torque wrench and apply approximately 2 Lb force to the cable with your finger (or Daniels SCTD013) at the line marked "TEST AREA."
- 1.1.6. If the cable breaks or pulls out of the ferrule, then the crimp is unacceptable and the tool indenter should be adjusted per section 1.2. If the cable touches either the side or bottom surface of the test area, then the crimp is unacceptable and the tool indenter should be adjusted per section 1.2.

1.2 INDENTER ADJUSTMENT

FIGURE 3

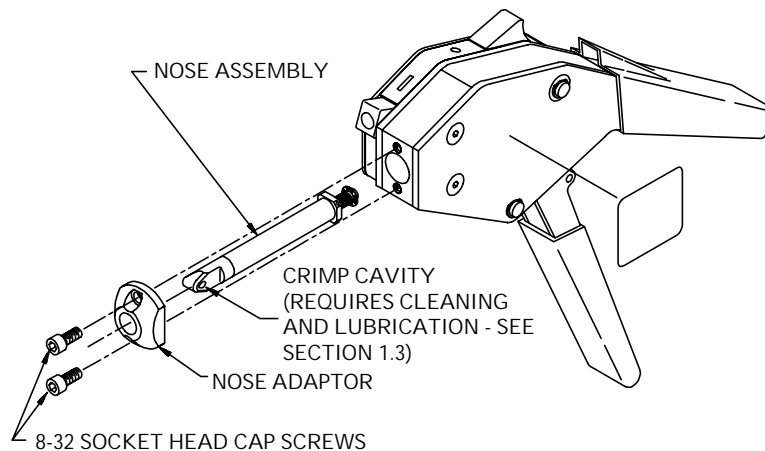

- 1.2.1. Remove the nose assembly by removing the two 8-32 socket head cap screws as shown in Figure 3.
- 1.2.2. Unlock the jamnut using the SCT32084 tool, and adjust the pushrod adjustment screw using a 1/4" straight edge screwdriver (see figure 4). Turn the pushrod adjustment screw clockwise to loosen the crimp (enlarge gaging dimensions). Turn the adjustment screw counterclockwise to tighten the crimp (reduce gaging dimensions). After each adjustment securely tighten the jam screw using the SCT32084 tool (while holding the adjustment screw stationary with the screwdriver) prior to the installation of the nose assembly.
- 1.2.3. Replace the nose assembly and the two 8-32 socket head cap screws. Prevent binding by alternately turning each screw a small amount until tight.

1.2.4. Check calibration as described in Section 1.1.

CAUTION: Tightening the crimp increases required hand forces during application and increases cable assembly tensile values. Loosening the crimp decreases required hand forces during application and decreases cable assembly tensile values.

Do not adjust the pushrod more than a quarter of a turn at a time. Severe adjustments may damage the tool.

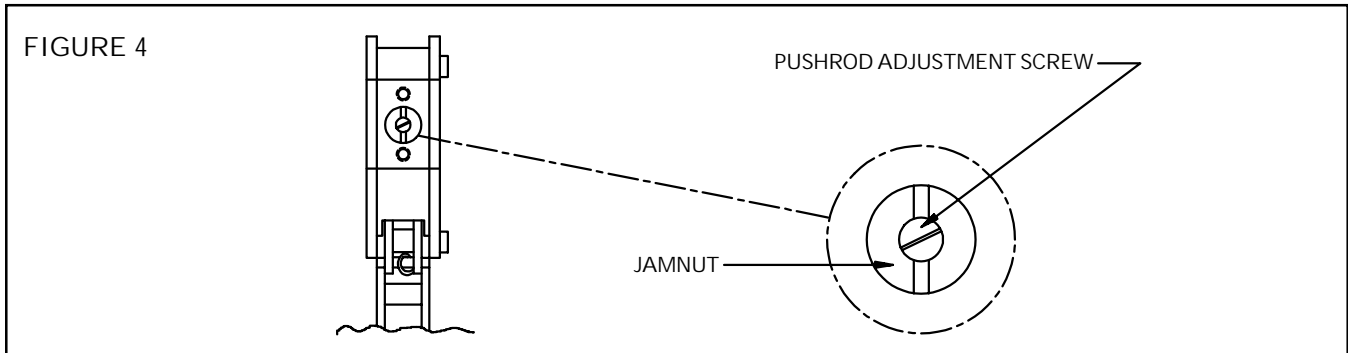

1.3. Maintenance of the Crimp Cavity

- 1.3.1. Debris can accumulate in the crimp cavity during use. This debris must be removed and the cavity oiled periodically depending upon use and environment. Ferrule sticking can occur if this procedure is not followed (see Figure 3).
- 1.3.2. Remove debris by gently scraping or brushing the crimp cavity. Blow any remaining debris from the cavity with air.
- 1.3.3. Coat the cavity with a light film of any lightweight synthetic or petroleum based oil after the cavity has been thoroughly cleaned.

2.0 PROPER CABLE INSTALLATION

- 2.1 Various examples of Safe-T-Cable® installation are shown in Figures 5 through 7. Although all possible combinations are not shown, three basic rules apply:
 - A) It is recommended that Safe-T-Cable® be installed in such a manner that any tendency for a fastener to loosen will be counteracted by an additional tension on the cable. Sharp turns in excess of 135° should be avoided. Installed Safe-T-Cable® should produce a positive or neutral pull on the fastener.
 - B) Safe-T-Cable® should be installed in two or three bolt patterns. Two bolt patterns being preferred when Safe-T-Cable® is applied to an even number of fasteners.

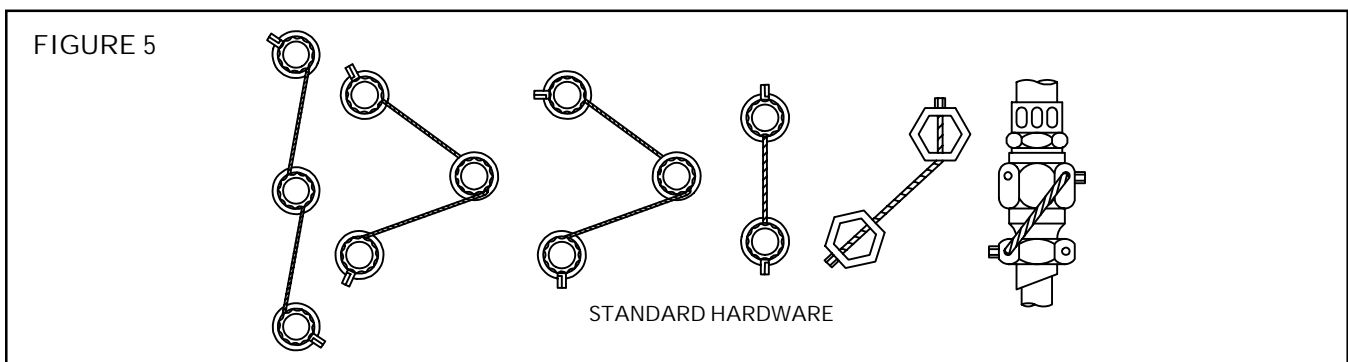

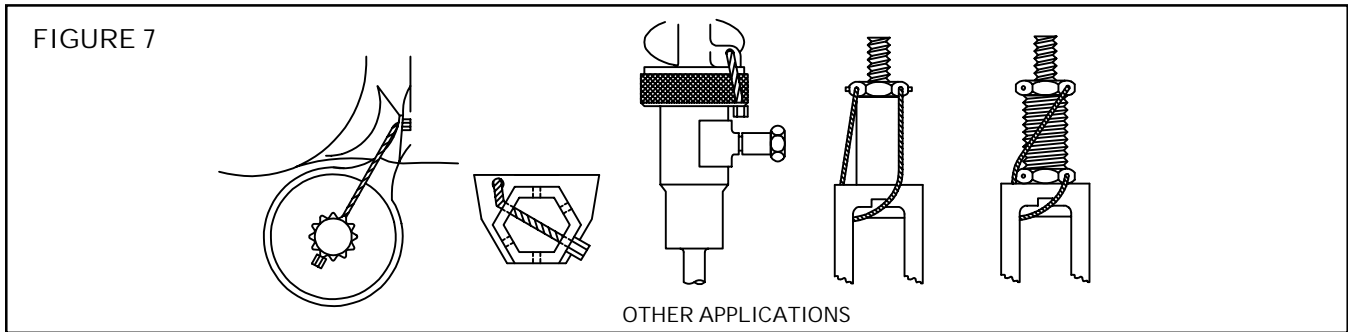
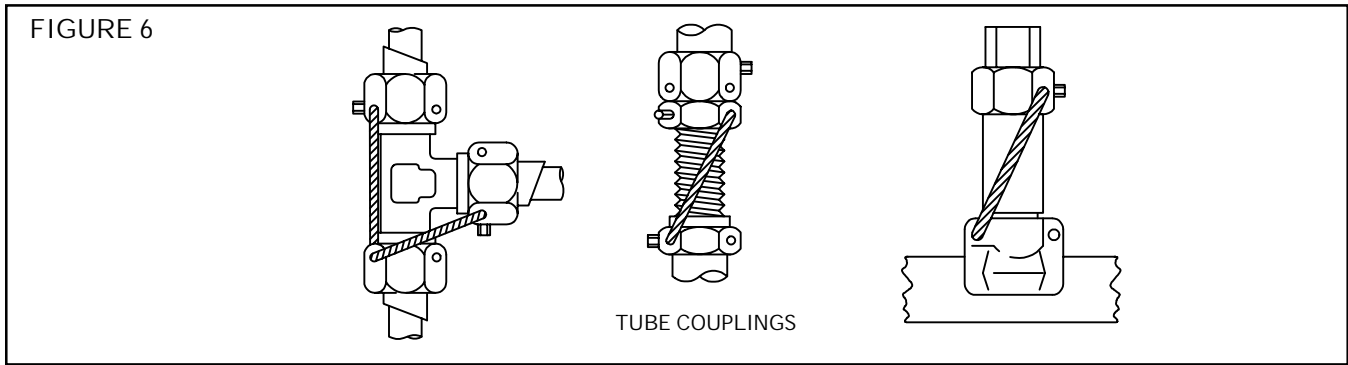

C) Maximum span of Safe-T-Cable® shall be six inches from end to end.

3.0 PROPER LOADING AND USE OF THE APPLICATION TOOL

3.1. Select the proper Safe-T-Cable® kit (see Section 5.0)

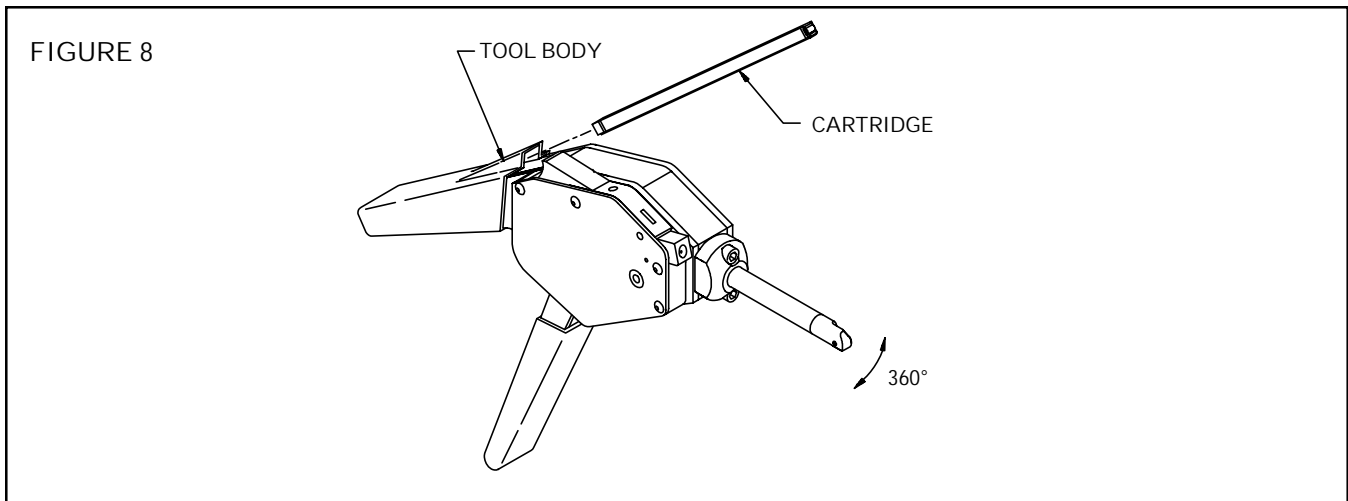

- 3.2. Install the cartridge supplied with the safe-T-Cable® kit into the tool body as shown in Figure 8.
- 3.3. Install the Safe-T-Cable® (supplied with the kit) through the bolts as described in Section 2.0.
- 3.4. The nose can rotate to any position. Rotate the nose to the desired position.
- 3.5. Insert the free end of the cable through the last ferrule in the cartridge as shown in Figure 9. Removed the ferrule by pulling the cable away from the end of the cartridge.

CAUTION: Do not release the free end of the cable until it has been inserted through the tool nose.

3.6 Insert the free end of the cable through the nose as shown in Figure 10. Slide the tool along the cable

FIGURE 9

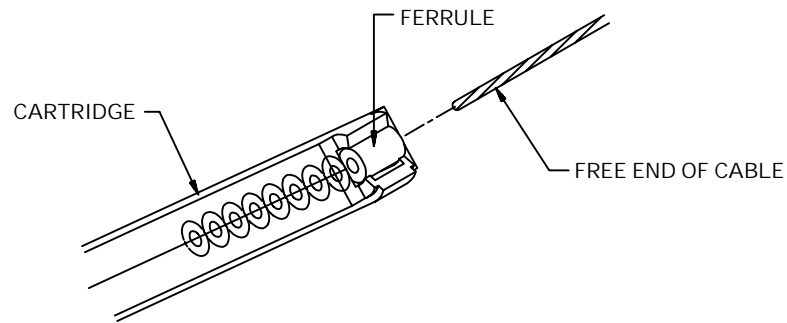
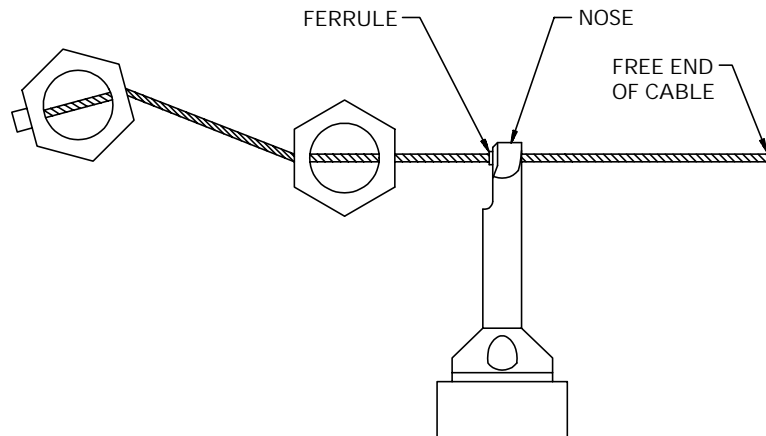

FIGURE 10



to the desired position. Make certain that the ferrule is fully seated in the nose.

- 3.7 Insert the free end of the cable into the cable entrance as shown in Figure 11. Continue to push the cable into the cavity. When the free end of the cable appears at the bottom of the tool, grab the cable

FIGURE 11

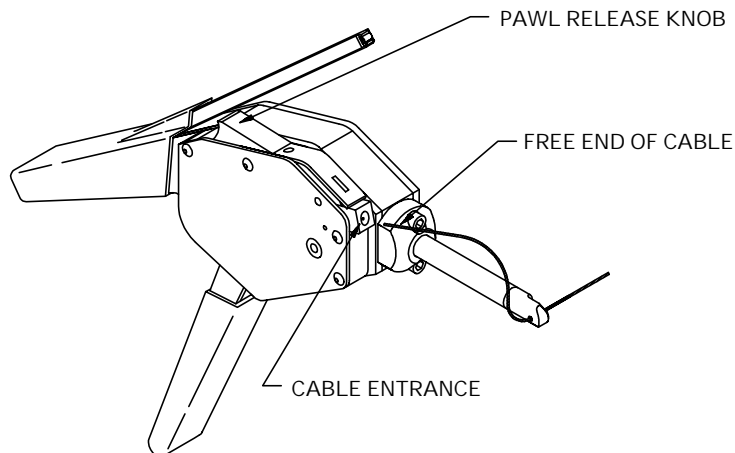

and pull the slack from the cable until resistance is felt.

- 3.8 Begin removing slack from the cable by repeatedly closing the tool handle, allowing the handle to open fully before closing again.

NOTE: Grip the cable as close to the free end as possible during insertion to prevent buckling.

- 3.9 When all slack is removed from the cable, snug the tool against the fastener by using several short strokes of the handle. Release the handle to the full open position and fully close the handles to affect crimping and cutting.

CAUTION: It is important in this final stroke to hold the tool as steady and perpendicular to the cable as possible while assuring that a full stroke is used to provide consistent tensioning of the cable (see Figure 12).

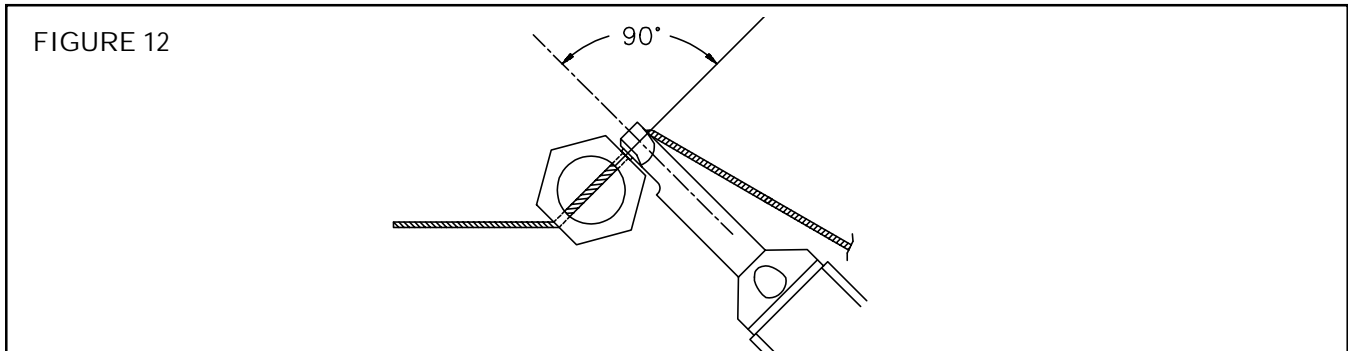

- 3.10. After crimping and cutting, release the tool handle and slide the tool off the crimped ferrule. Pull the excess cable from the tool.

4.0 VERIFICATION OF INSTALLATION

- 4.1 Verify proper tension of the cable. Refer to Table 1, Figure 13 for Safe-T-Cable® flex limits.

A inch (mm)	B inch (mm)	C inch (mm)
0.5 (12.7)	0.125 (3.18)	0.062 (1.59)
1.0 (25.4)	0.250 (6.35)	0.125 (3.18)
2.0 (50.8)	0.375 (9.52)	0.188 (4.76)
3.0 (76.2)	0.375 (9.52)	0.188 (4.76)
4.0 (101.6)	0.500 (12.70)	0.250 (6.35)
5.0 (127.0)	0.500 (12.70)	0.250 (6.35)
6.0 (152.4)	0.625 (15.88)	0.312 (7.94)

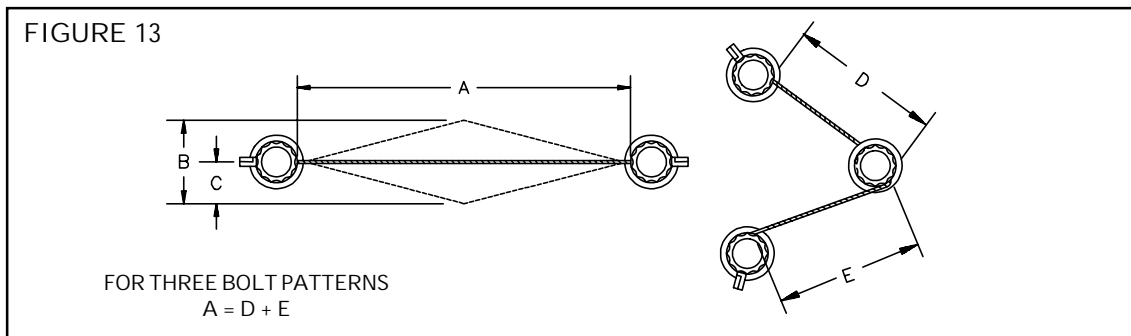

- 4.2 Verify that the cable was installed through the bolts in accordance with Section 2.0
- 4.3 Verify that the cable was cut flush at the end of the ferrule with no strand extending more than 1/32 inch from the end of the ferrule.
- 4.4 Visually inspect the cable for any nicks or other damage that may have occurred during installation.

5.0 SAFE-T-CABLE® SYSTEM PART NUMBERS

5.1 Tool/Accessory part numbers:

APPLICATION TOOLS (COMPLETE)		
TOOL PART NUMBER	NOMINAL CABLE DIAMETER	NOSE LENGTH
SCT203	.020	3 INCHES
SCT207	.020	7 INCHES
SCT323	.032	3 INCHES
SCT327	.032	7 INCHES
SCT403	.040	3 INCHES
SCT407	.040	7 INCHES

INTERCHANGEABLE NOSES		
NOSE PART NUMBER	NOMINAL CABLE DIAMETER	NOSE LENGTH
SCTN20-3	.020	3 INCHES
SCTN20-7	.020	7 INCHES
SCTN32-3	.032	3 INCHES
SCTN32-7	.032	7 INCHES
SCTN40-3	.040	3 INCHES
SCTN40-7	.040	7 INCHES

All sizes and lengths of noses are interchangeable using the same basic tool.
 Indenter calibration must be checked whenever the nose is changed. See Section 1.1.

CALIBRATION TOOLS	
TOOL PART NUMBER	DESCRIPTION
SCT-TB1	TEST BLOCK
SCTD0001	TORQUE WRENCH (20-150 IN LB)
SCTD013	RETENTION TESTER

SAFE-T-CABLE® DIAGONAL CUTTERS
PART NUMBER 45 - 6N

5.2 SAE to DMC part number cross reference

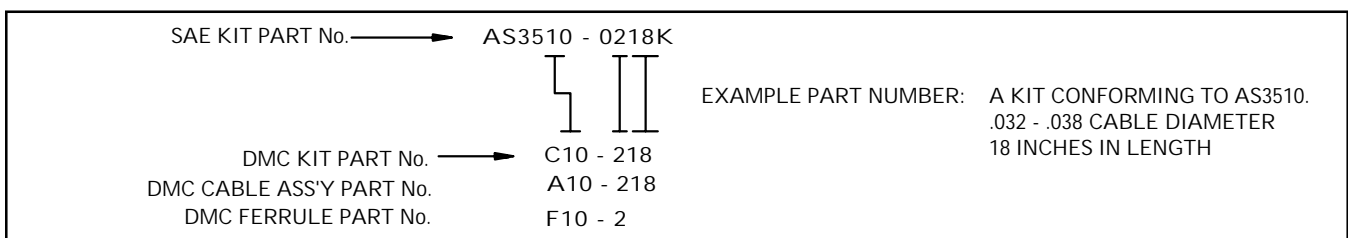
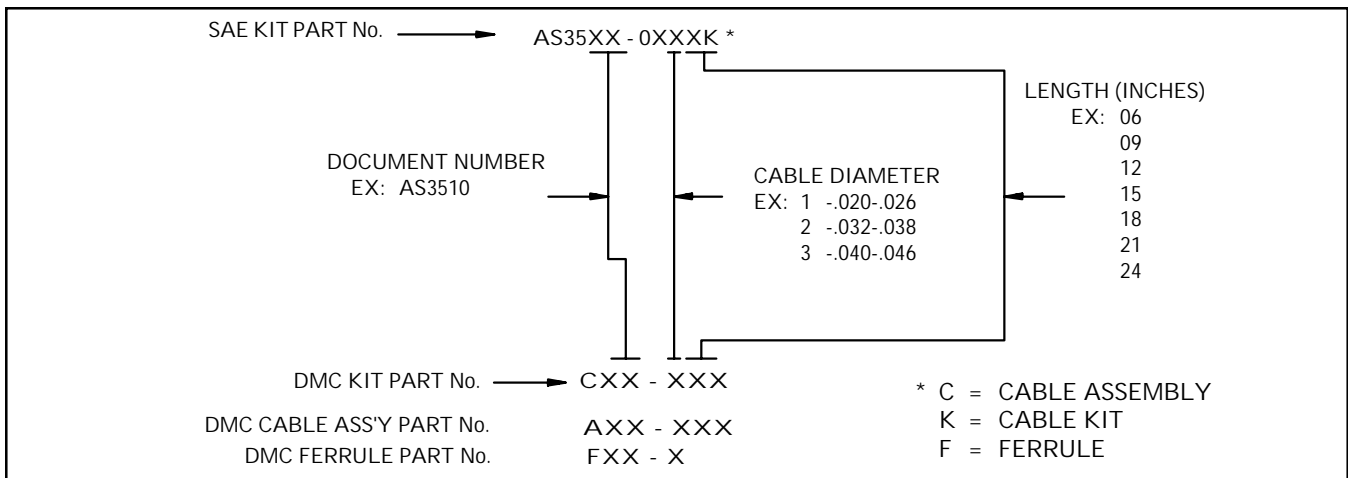

DANIELS MANUFACTURING CORP. 526 THORPE ROAD, ORLANDO, FL 32824, USA
 PHONE (407) 855-6161 • FAX (407) 855-6884 • WWW.DMCTOOLS.COM • E-MAIL: DMC@DMCTOOLS.COM

5.3 Daniels Safe-T-Cable® Kit part numbers

TABLE 2 - .020, .032, .040 NOMINAL DIAMETER CABLE KITS				
KIT PART NUMBER	(D) CABLE DIAMETER	COMPONENT MATERIAL	(L) LENGTH (INCHES)	MINIMUM PULL-OFF LOAD lbf (N)
C10-106	.020 - .026 (1 x 7 STRAND)	UNS S32100 CORROSION AND HEAT RESISTANT ALLOY (AMS5689)	6	30 (133.4)
C10-109			9	
C10-112			12	
C10-115			15	
C10-118			18	
C10-121			21	
C10-124			24	
C10-206	.032 - .038 (3 x 7 CABLE)	UNS S32100 CORROSION AND HEAT RESISTANT ALLOY (AMS5689)	6	70 (311.4)
C10-209			9	
C10-212			12	
C10-215			15	
C10-218			18	
C10-221			21	
C10-224			24	
C10-306	.040 - .046 (7 x 7 CABLE)	UNS S32100 CORROSION AND HEAT RESISTANT ALLOY (AMS5689)	6	110 (489.3)
C10-309			9	
C10-312			12	
C10-315			15	
C10-318			18	
C10-321			21	
C10-324			24	

A Safe-T-Cable® kit includes cable with an end fitting attached and a ferrule. kits are sold and packaged in groups of 50.

5.4 Daniels Safe-T-Cable® Ferrule Part Numbers:

TABLE 3 - FERRULES		
FERRULE PART NUMBER	FOR NOMINAL CABLE DIAMETER	MATERIAL
F10-1	.020	UNS S32100
F10-2	.032	UNS S32100
F10-3	.040	UNS S32100

Daniels ferrules are sold in groups of 50 and are packaged in a cartridge.

TABLE 4 - ELONGATED FERRULES FOR LOW PROFILE APPLICATIONS		
FERRULE PART NUMBER	FOR NOMINAL CABLE DIAMETER	MATERIAL
F10-08	.020	UNS S32100
F10-04	.032	UNS S32100
F10-07	.040	UNS S32100

Consult factory for information concerning low profile installations.

DANIELS MANUFACTURING CORP. 526 THORPE ROAD, ORLANDO, FL 32824, USA
 PHONE (407) 855-6161 • FAX (407) 855-6884 • WWW.DMCTOOLS.COM • E-MAIL: DMC@DMCTOOLS.COM

5.5 Daniels Safe-T-Cable® Assembly part numbers

TABLE 5 - .020, .032, .040 NOMINAL DIAMETER CABLE ASSEMBLIES				
ASSEMBLY PART NUMBER	(D) CABLE DIAMETER	COMPONENT MATERIAL	(L) LENGTH (INCHES)	MINIMUM PULL-OFF LOAD lbf (N)
A10-106	.020 - .026 (1 x 7 STRAND)	UNS S32100 CORROSION AND HEAT RESISTANT ALLOY (AMS5689)	6	30 (133.4)
A10-109			9	
A10-112			12	
A10-115			15	
A10-118			18	
A10-121			21	
A10-124			24	
A10-206	.032 - .038 (3 x 7 CABLE)	UNS S32100 CORROSION AND HEAT RESISTANT ALLOY (AMS5689)	6	70 (311.4)
A10-209			9	
A10-212			12	
A10-215			15	
A10-218			18	
A10-221			21	
A10-224			24	
A10-306	.040 - .046 (7 x 7 CABLE)	UNS S32100 CORROSION AND HEAT RESISTANT ALLOY (AMS5689)	6	110 (489.3)
A10-309			9	
A10-312			12	
A10-315			15	
A10-318			18	
A10-321			21	
A10-324			24	

A Safe-T-Cable® assembly consist of a cable and end fitting attached. Safe-T-Cable® assemblies are sold packaged in groups of 50.

Contact the factory for information on INCONEL Safety Cable Kits.

Daniels Manufacturing Corp. offers complete refurbishing and recalibration services.

DMC specially engineers and manufactures complete tool kits to satisfy individual customer requirements, such as total aircraft support, general shop maintenance or production, on board ship and vehicle service, etc.

INVALIDATION OF LIMITED WARRANTY

This manual is provided to those owners of Daniels Manufacturing Corporation (DMC) products who have elected to conduct in-house repairs of such products and who thereby consent to waive any rights which they otherwise might have had under the DMC limited warranty applicable to such products.

DMC provides complete repair and maintenance service for all of its products. Owners of DMC products are warned that any tampering, including partial or complete disassembly of the product or attempted repairs of the product will invalidate the limited warranty applicable to said product.

LIMITATION OF LIABILITY

Daniels Manufacturing Corporation (DMC) is not liable for consequential or special damages of any nature or kind resulting from the use, or misuse, of any of its products. Owners and users of (DMC) products assume full responsibility for instructing their employees in the proper and safe use of such products.

LIMITED WARRANTY

Daniels Manufacturing Corporation (DMC) warrants each new product sold by it to be free from defects in material and workmanship under normal use and service. DMC's obligation under this warranty is limited to the free correction or, at DMC's option, the refund of the purchase price of any such product which proves defective in normal service within ninety (90) days after delivery to the first user, provided that the product is returned to DMC with all transportation charges prepaid in which shall appear to DMC's satisfaction, after DMC's inspection, to have been defective in material or workmanship, it being understood that DMC products are not consumer products. This warranty shall not cover any damage to any product which, in the opinion of DMC, was caused by normal wear, misuse, improper operation, tampering, neglect or accident. This warranty is in lieu of all other warranties express or implied. No warranty, express or implied, is made or authorized to be made or assumed with respect to products of Daniels Manufacturing Corporation other than those herein set forth.

Mouser Electronics

Authorized Distributor

Click to View Pricing, Inventory, Delivery & Lifecycle Information:

[Daniels Manufacturing:](#)

[SCT327Y](#) [SCT327SG](#)